

# COSMOS<sup>2</sup>

EXPERIENCE REVOLUTIONARY HYGIENE REDEFINED



# VISION MADE REAL

The COSMOS<sup>2</sup> series combines advanced technology & sleek design to redefine hygiene.

It includes Towel Dispensers Sensor & Autocut, Sensor & Manual Dispensers for soap, disinfection & seat cleaner, complemented by a double roll toilet paper dispenser, all designed for optimal efficiency. This series cuts consumption, saves costs & promotes sustainability with energy-efficient designs.

Investing in COSMOS<sup>2</sup> enhances functionality & supports eco-friendly operations.

PRE-ORDER NOW



[www.jm-metzger.group/kontakt](http://www.jm-metzger.group/kontakt)





True German craftsmanship,  
developed & produced in Germany.

# TOWEL DISPENSERS



## SENSOR

ITEM NUMBER C2\_COSMOS-4XXX

-  **Touch free technology**  
Hygienic, contactless operation
-  **Single-sheet dispensing**  
Available in multiple towel sizes for versatile application
-  **Up to 40% paper reduction**  
Ensures high efficiency with significant paper savings
-  **Battery or mains operation**  
LED light signals for battery replacement

The Towel Dispenser SENSOR delivers hygienic, touch-free single-sheet dispensing with efficient paper usage & a compact design that fits seamlessly into any space.

# TOWEL PAPER REFILLS



## SENSOR | AUTOCUT

Our towel roll range offers various options to meet every requirement – from different plies & lengths to specific performance features. Designed for high to ultra-high yield, these rolls ensure maximum efficiency in professional hygiene environments. The focus lies on cost-effective use, helping to significantly reduce storage space, resource consumption & internal operational capacity. A smart choice for sustainable & economical hygiene management.

### PREMIUM TAD C2-HTZ100K

2-ply, 100m PREMIUM TAD quality, 6 rolls pu



### SMART CLASSICO C2-HTZ109K

2-ply, 150m, 100% cellulose, 6 rolls pu



### SMART ECO C2-HTZ205K

1-ply, 230m PREMIUM TAD quality, 6 rolls pu







### ECO C2-HTZ109K-ECO

2-ply, 140m, 100% recycled paper, 6 rolls pu



## AUTOCUT

ITEM NUMBER C2\_COSMOS-3XXX

-  **Push button function**  
Prevents paper jams & blockages completely
-  **Remnant roll function**  
Zero waste, ensures complete roll usage
-  **Premium cutting mechanism**  
For a flawless, precise towel cut
-  **Non-electric design**  
No battery or ongoing operational costs

The Towel Dispenser AUTOCUT features a premium cutting mechanism, zero-waste remnant roll function & push-button operation – ensuring smooth, reliable use without electricity or maintenance.



## FINESSING SOLUTION

Thanks to the innovative Quick Change Holder & integrated guide rail in the Towel Dispensers SENSOR & AUTOCUT, inserting a new towel roll is remarkably fast and intuitive. The system ensures smooth threading & secure positioning within seconds—eliminating downtime & making roll changes effortless, even during busy operations. This time-saving solution enhances workflow efficiency and supports a seamless hygiene routine.

Its compact size allows it to integrate seamlessly into any environment, making it the ideal choice for space-conscious, professional hygiene settings.

-  **Quick Change Holder**  
Effortless, fast refill system

 **43 cm (H) x 33 cm (W) x 21 cm (D)**  
Kompakte Maße, geschaffen für jedes Interieur

PRE-ORDER NOW



[www.jm-metzger.group/kontakt](http://www.jm-metzger.group/kontakt)



# UNIVERSAL DISPENSER



The UNIVERSAL dispenser features a unified design and is available in multiple versions for disinfection, foam soap, seat cleaner & heavy-duty cleaner—offering a consistent look across all hygiene applications.

## SENSOR

ITEM NUMBER C2\_COSMOS-5XXX

- Touch free technology**  
Hygienic, contactless operation
- Ultra high efficiency**  
Up to 2,500 applications
- 3 adjustable dosages**  
For optimized savings
- Rechargeable battery powered**  
LED signals for recharge alerts
- Eco-mode & Speed-mode**  
Smart self-regulating system to save energy
- 25,5 cm (H) x 11,5 cm (W) x 10,5 cm (D)**  
Compact size, effortlessly integration in any space

Also available as MANUAL dispensers.  
ITEM NUMBER C2\_COSMOS-1XXX

# TOILET PAPER DISPENSER



The Toilet Paper Dispenser DUAL ROLL offers smart single-sheet dispensing with continuous paper availability & dual-roll capacity – maximizing efficiency in a compact format.

## DUAL ROLL

ITEM NUMBER C2\_COSMOS-2XXX

- Automatic push function**  
Roll always pushed to the front, ensuring constant accessibility.
- Smart single-sheet dispensing mechanism**  
Reduces waste, ensures hygiene & enhances cost-efficiency
- Up to 40% paper reduction**  
For optimized savings
- Utilizing 2 long life rolls concurrently**  
Extended use, LED alert for roll change
- Integrated braking mechanism**  
Ensures controlled dispensing
- 33 cm (H) x 15 cm (W) x 17,5 cm (D)**  
Compact size, effortlessly integration in any space

## WIDE RANGE OF REFILLS

A wide variety of refill options is available to suit every hygiene need. The universal vacuum-sealed special cartridge comes with a pre-installed, optimized pump that ensures efficient & precise dispensing. With an ultra-high yield of 1,000 to 2,500 applications depending on the filling & extended shelf life thanks to the sealed system, it offers maximum reliability & minimal maintenance.

**FOAM SOAP**  
C2-FS1000

1 L, up to 2.500 app., 6 cartridges pu  
Variants: Mild, antibacterial, fragrance-free

**DISINFECTION**  
C2-CDM1000

**VAH** ROBERT KOCH INSTITUT ÖGHMP

**SEAT CLEANER**  
C2-FWC1000

1 L, up to 2.500 app., 6 cartridges pu  
Foamy, disinfectant effect

**COURSE CLEANER**  
C2-S-TB1000

1 L, up to 2.000 app., 6 cartridges pu  
Alkali-, plastic- & soap-free

**LONG LIFE 2L**  
C2-THR2502K

2-ply, 100 m, 32 rolls pu

**LONG LIFE 2L MAXI**  
C2-THR3502K

2-ply, 140 m, 32 rolls pu

**LONG LIFE 3L**  
C2-THR3503K

3-ply, 90 m, 32 rolls pu



PRE-ORDER NOW



[www.jm-metzger.group/kontakt](http://www.jm-metzger.group/kontakt)

## VERSATILE. EFFICIENT. ESSENTIAL.

A broad range of toilet paper rolls is available, offering various plies & lengths to suit every requirement. Thanks to an advanced manufacturing process, the rolls achieve ultra-high yield while remaining compact—ideal for high-traffic areas. All options are EU Ecolabel & FSC certified, feature a recyclable core & stand for both efficiency and sustainability.



PRE-ORDER NOW



[www.jm-metzger.group/kontakt](http://www.jm-metzger.group/kontakt)

# PUREWIPE

SMART MULTI-WIPE DISPENSER

A unique, innovative hygiene system dispensing dry towels or wet wipes in variable lengths.



Wipe



METZGER  
SYSTEMS

Disinfect



# THE INNOVATION

In a world craving innovation, I stand out.  
My precision & sustainability redefine sanitation,  
merging hygiene with eco-consciousness.

I lead boldly, setting new benchmarks & exceeding expectations.

I am the future of hygiene,  
I am unique,  
I am PUREWIPE.

PRE-ORDER NOW



[www.jm-metzger.group/kontakt](http://www.jm-metzger.group/kontakt)

True German craftsmanship,  
developed & produced in Germany.

# SMART MULTI-WIPE DISPENSER

## PUREWIPE

C2\_COSMOS-PWXXX

 **Touch free & button technology**  
Hygienic, contactless operation

 **Quick change holder**  
Effortless, fast refill system

 **Various wipe sizes**  
For optimized savings

 **Battery, accumulator or power cord operation**  
LED light signals for battery replacement indicator

 **Smart connection via cloud & app (optional)**  
Fill level inquiry, dispenser data extraction & more

 **Patented system**  
Aligns with the latest requirements of the Robert Koch Institute

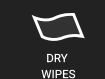
 DRY WIPES

 WET DISINFECT WIPES

 VERY WET DISINFECT WIPES

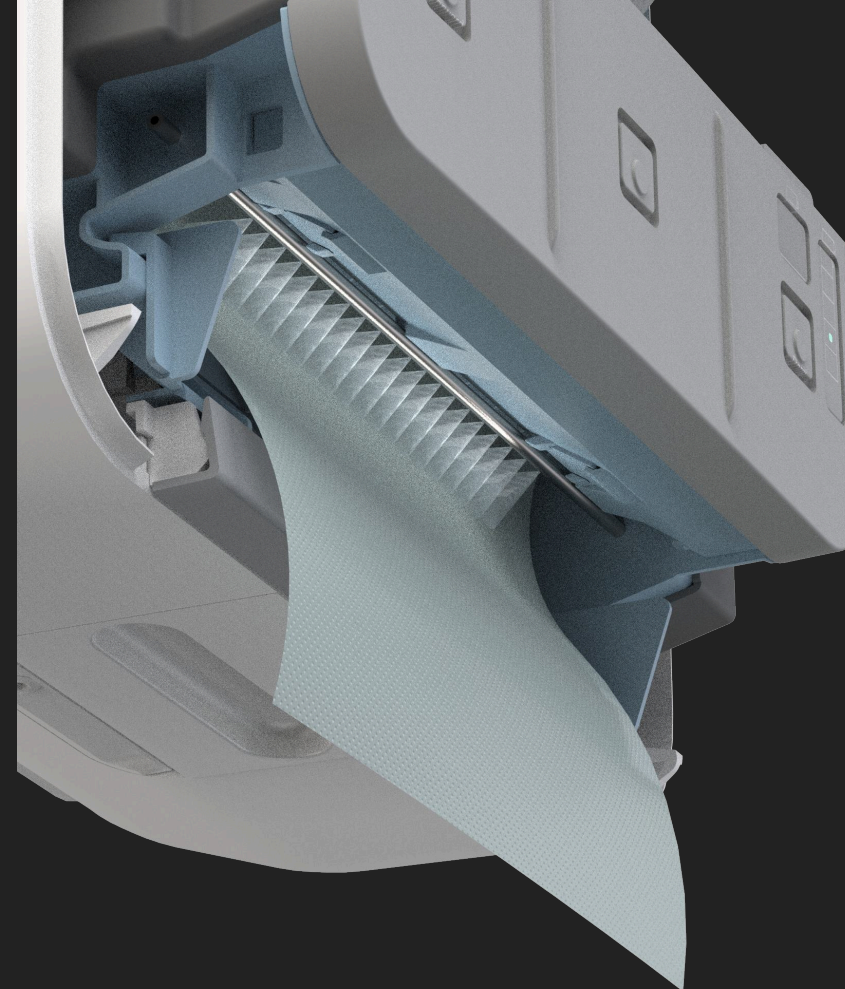
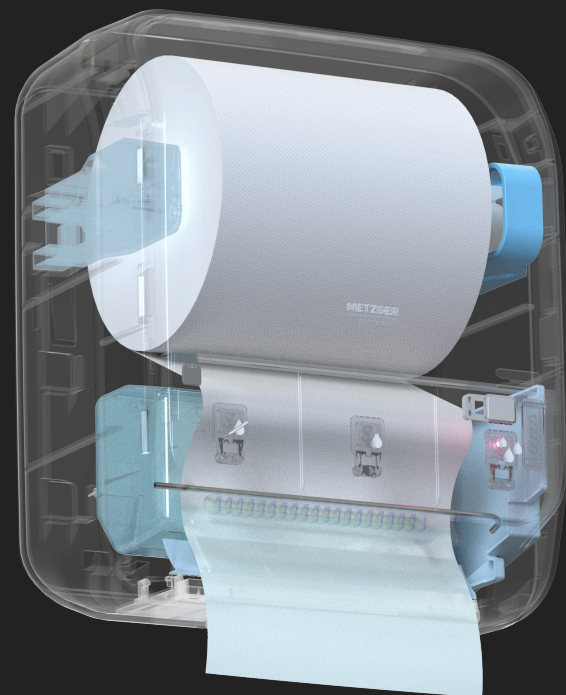

## SPOTTLESS HYGIENE

 **Self cleaning system**  
Flushes internal parts after each use to ensure hygiene & prevent contamination

 **2.000 ml tank**  
High-capacity, reduced maintenance

 **150-meter roll, 2-ply, approx. 1.000 sheets**  
Ideal length for lasting utility

 **100% cellulose**  
Soft and environmentally conscious, devoid of conventional wet wipes' plastic

 **No drying out**  
Maintains moisture, longer enhanced efficiency

ROBERT KOCH INSTITUT



Aligns with the latest requirements of the Robert Koch Institute

## NEXT LEVEL HYGIENE

The PUREWIPE is a truly unique innovation—designed to set new standards in hygiene & modern surface care. It combines advanced design with forward-thinking technology, offering a solution unlike anything before it.



## SMART SUPPLY SOLUTIONS

Designed for performance & efficiency, the paper towel rolls offer high-yield options tailored to professional hygiene needs. The disinfectant, a 2-liter cartridge, ensures long-lasting application with minimal maintenance – perfectly suited for high-traffic environments.

**SMART CLASSICO**  
C2-HTZ109K

2-ply, 150 m, 100% cellulose, 6 rolls pu



**DISINFECTION**  
C2-OD1200

1 L, up to 2.000 app., 1 cartridge pu



Building on this, the dispenser system integrates seamlessly into any professional setting—delivering touch-free precision, optimized resource use & a reliable hygiene workflow. It's smart, user-friendly design reduces refill frequency, enhances safety & supports consistent standards across all applications.

PRE-ORDER NOW



[www.jm-metzger.group/kontakt](http://www.jm-metzger.group/kontakt)

SMART   
CONNECTION

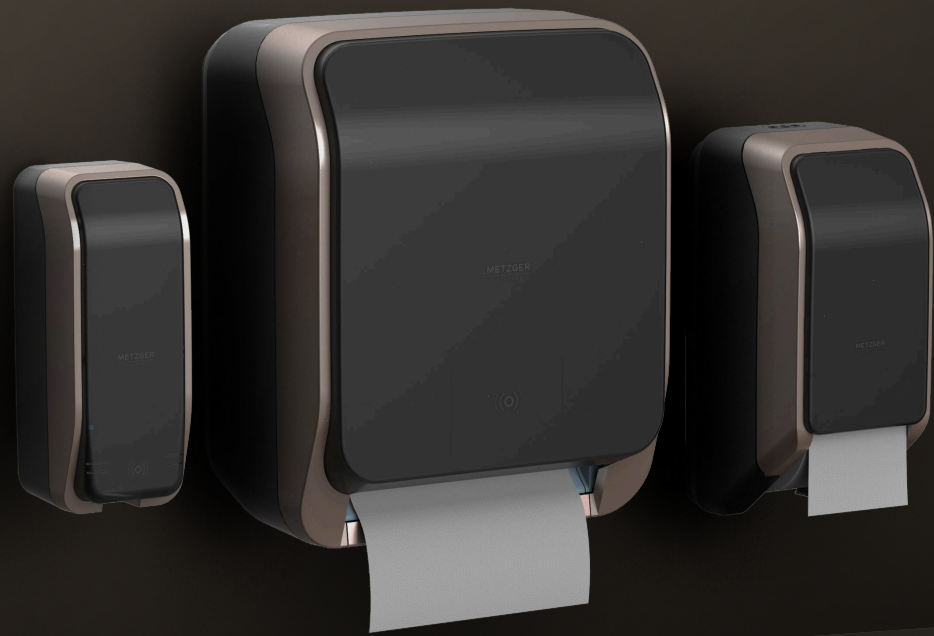



# BE THE FIRST

Touch base & be the first to experience the innovation that elevates hygiene.

## WHAT'S DATA WITHOUT USEFUL ANSWERS?

Your personal AI hygiene expert – delivering real-time answers, 24/7. For every role, from management board & sourcing department to facility management, cleaning staff & more.

 **AI analysis & insights**  
Smart algorithms monitor usage to provide data-driven hygiene optimization

 **Statistics and heatmaps**  
Real-time visuals reveal usage intensity & location patterns at a glance

 **Optimized refill routes**  
Intelligent tracking minimizes refill effort & travel time

 **Automated purchase lists**  
System-generated lists simplify reordering & ensure continuous supply

 **Browser based app**  
Easily accessible from any device, no installation required

 **Secure data encryption**  
All information is protected through advanced encryption standards



**EXPLORE NOW**  
[www.jm-metzger.group/sortiment](http://www.jm-metzger.group/sortiment)



PRE-ORDER NOW



[www.jm-metzger.group/kontakt](http://www.jm-metzger.group/kontakt)



# The Art Of Creating Innovation

Made In Germany

JM Metzger Group  
Headquarters  
Nordstraße 45  
D-74219 Möckmühl

[www.jm-metzger.de](http://www.jm-metzger.de)